

Series LXA guide unit, double acting

Technical details

Operating pressure	1 ... 10 bar
Temperature range	-20°C ... +80°C (-10°C...+150°C with FKM-seals)
Operating speed	50 ... 500 mm/s
Medium	Filtered, oil-free and dried compressed air according to ISO 8573-1:2010, Class 7:2:4, instrument air, free of aggressive additives. Alternatively the pressure dew point must be at least 10°C below lowest occurring ambient temperature.
Materials	Profile: Al (anodized) Flange plate: Steel (nickel plated) Piston rod: steel hard chrome plated (optional 1.4301) Guide rod: steel hard chrome plated (optional 1.4301) Seals: PU, NBR (optional FKM)

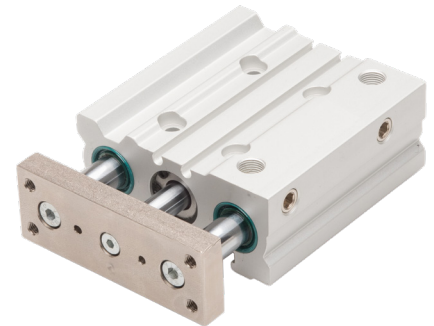

Double acting pneumatic cylinder with magnetic piston and built-in cushioning rings. The sensors can be installed directly into the sensor grooves of the Al-profile.

The integrated cylinder and guide unit ensures precise and accurate movement.

Standard stroke lengths in table below, additional lengths on request.

Versions

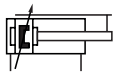

-0**
double acting, adjustable cushioning,
with magnetic piston, guide unit



-2**
double acting, built-in cushioning rings,
with magnetic piston, guide unit

Order code

LXA-**-***-***-***			
Series	LXA	Seals	0 piston rod seal PU, other seals NBR
Guide	G bronze bearings K ball bearings		2 all seals FKM
Piston Ø	016 16 mm 020 20 mm 025 25 mm 032 32 mm 040 40 mm 050 50 mm 063 63 mm	Materials	0 piston rod and guide rods stainless steel 5 piston rod and guide rods steel, hard chrome plated
		Cushioning	0 adjustable cushioning 2 built-in cushioning rings
		Stroke (mm)	XXX max. 200 mm Standard see dimensions

Technical data

Model-no.:	LXA-016-...	LXA-020-...	LXA-025-...	LXA-032-...	LXA-040-...	LXA-050-...	LXA-063-...
Piston Ø (mm)	16	20	25	32	40	50	63
Force at 6 bar (N)	Extension	109	170	265	434	678	1060
	Retraction	81	127	204	326	570	890
Connection	M5	G1/8	G1/8	G1/8	G1/8	G1/4	G1/4

Series LXA

guide unit, double acting

Technical information

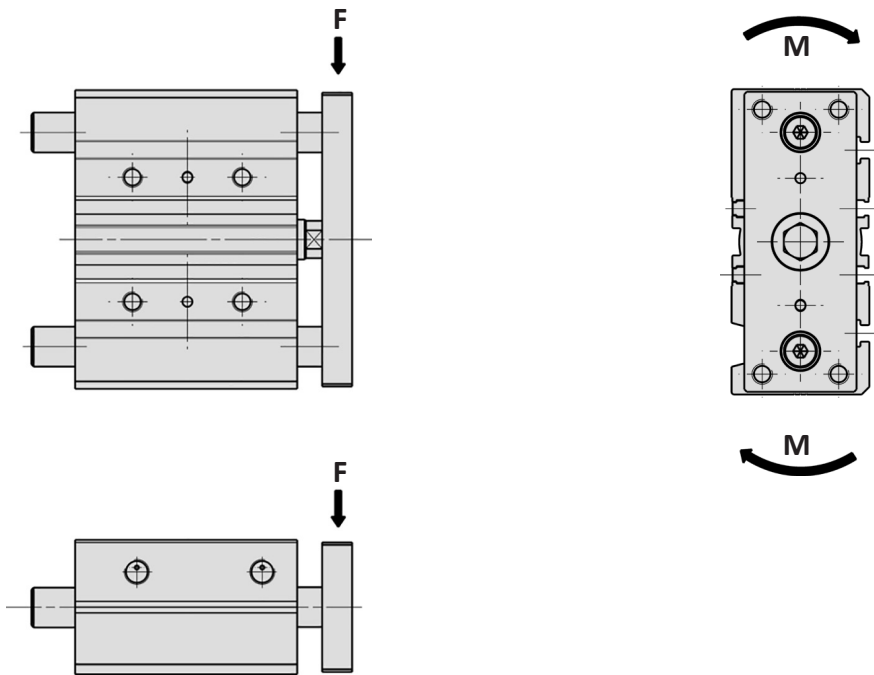

Mounting examples

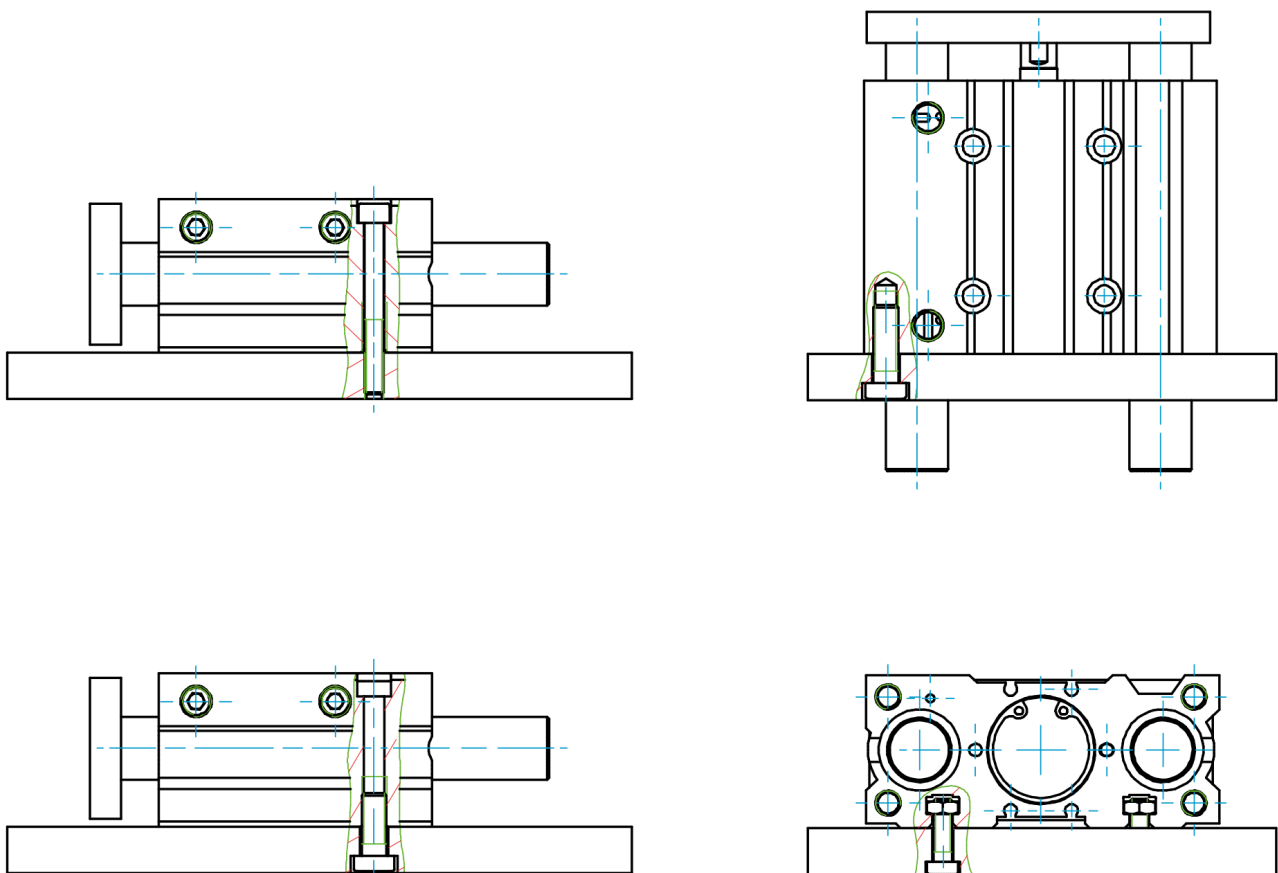

Technical information

Maximal Load F (N) LXA-G

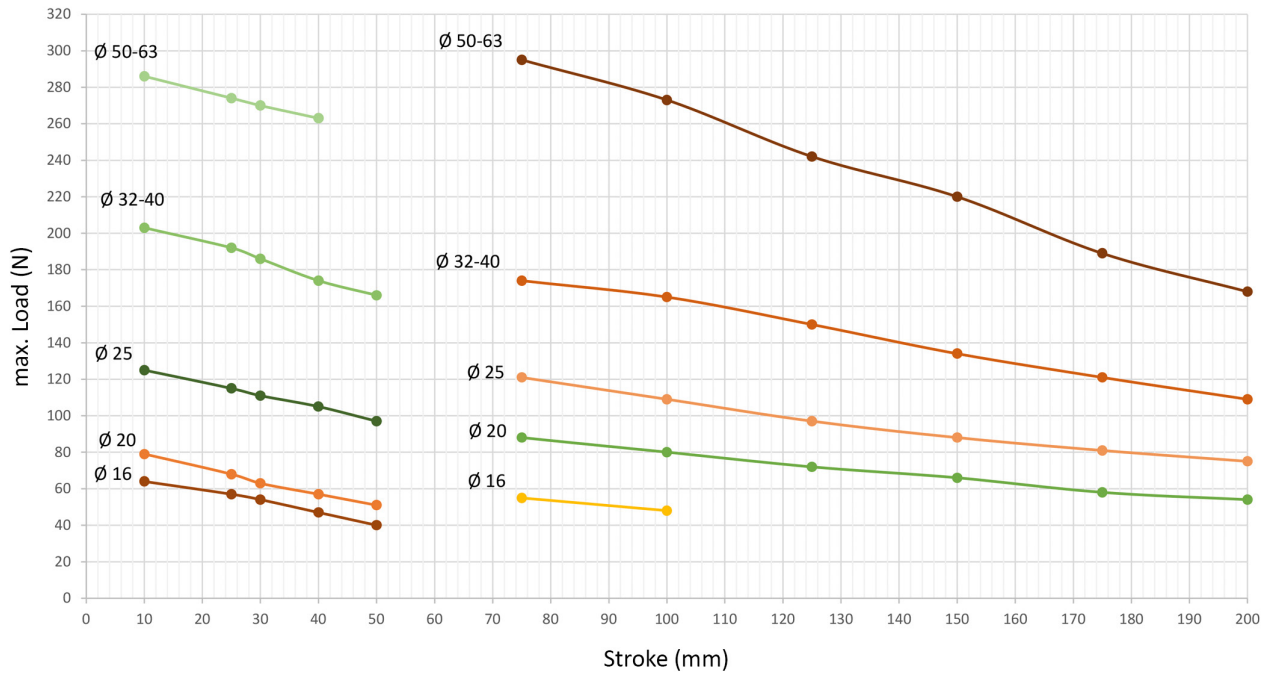

Maximal Torque M (Nm) LXA-G

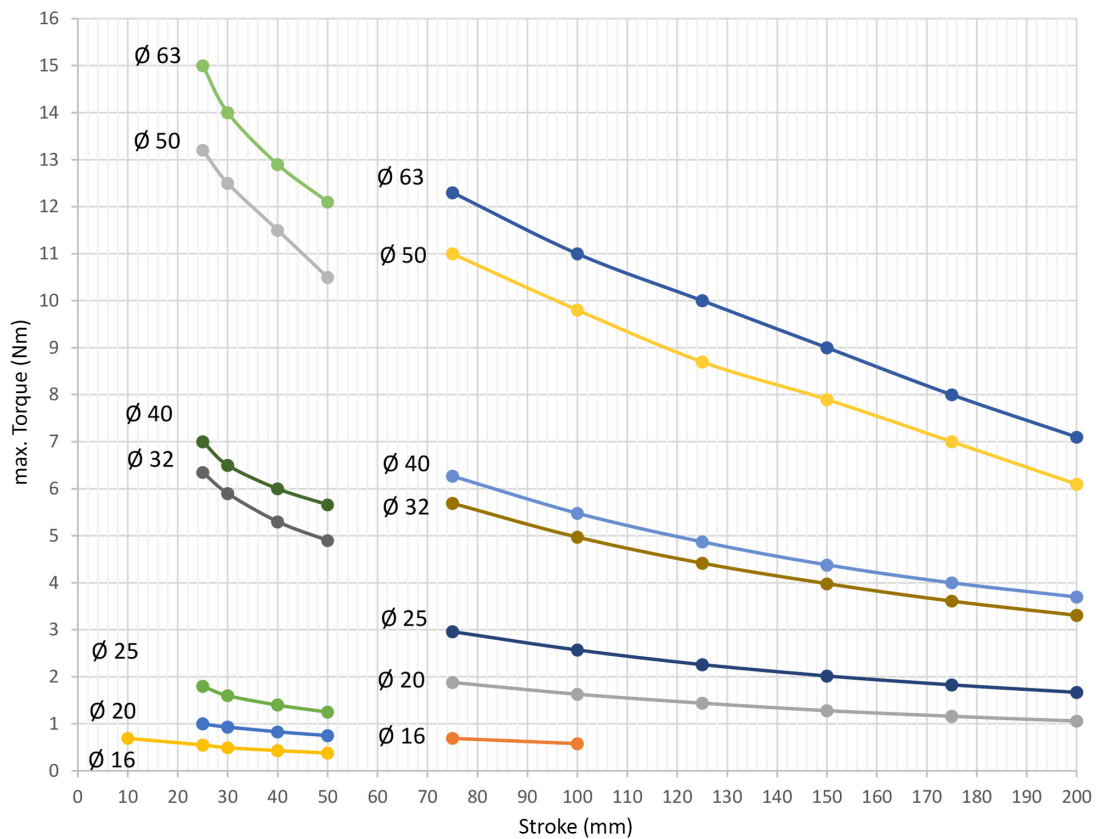

Series LXA

guide unit, double acting

Technical information

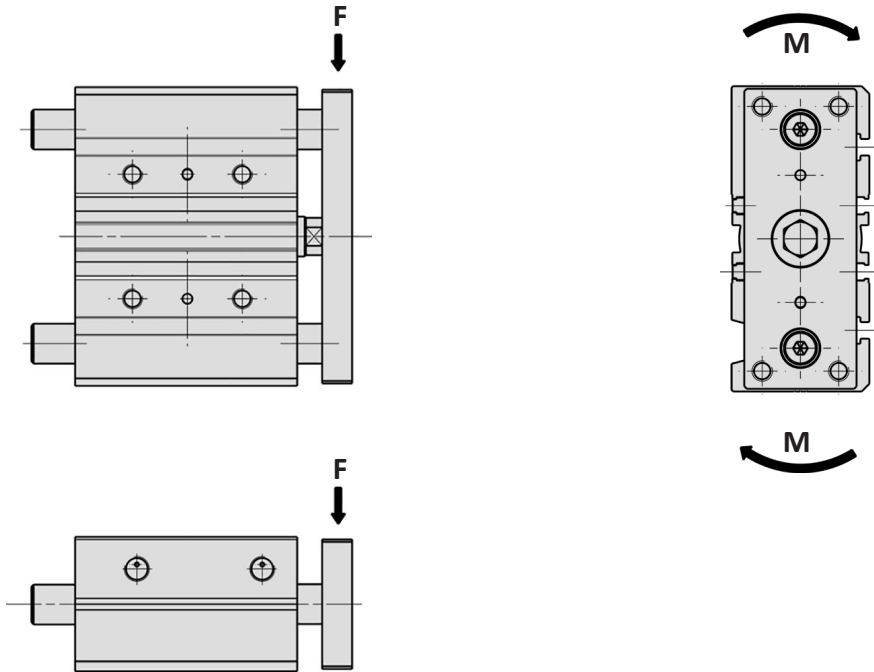

Technical information

Maximal Load F (N) LXA-K

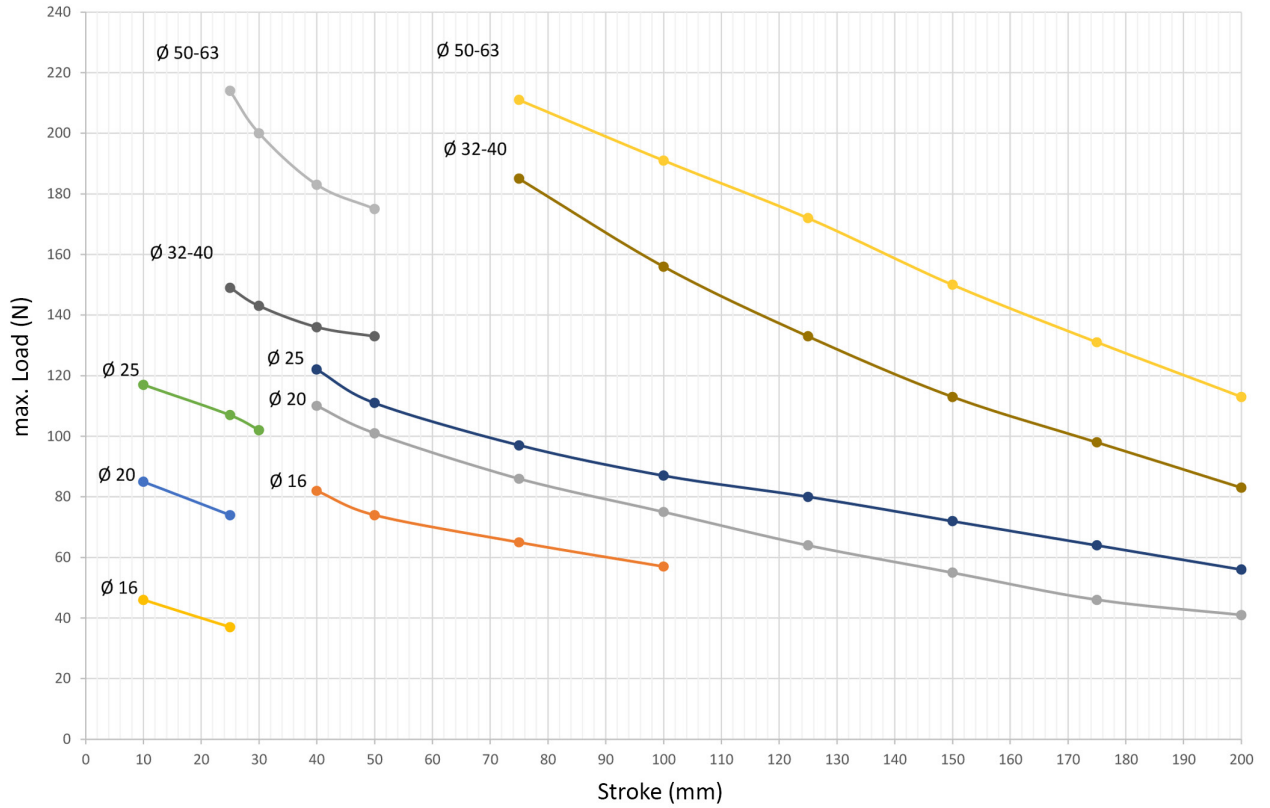

Maximal Torque M (Nm) LXA-K

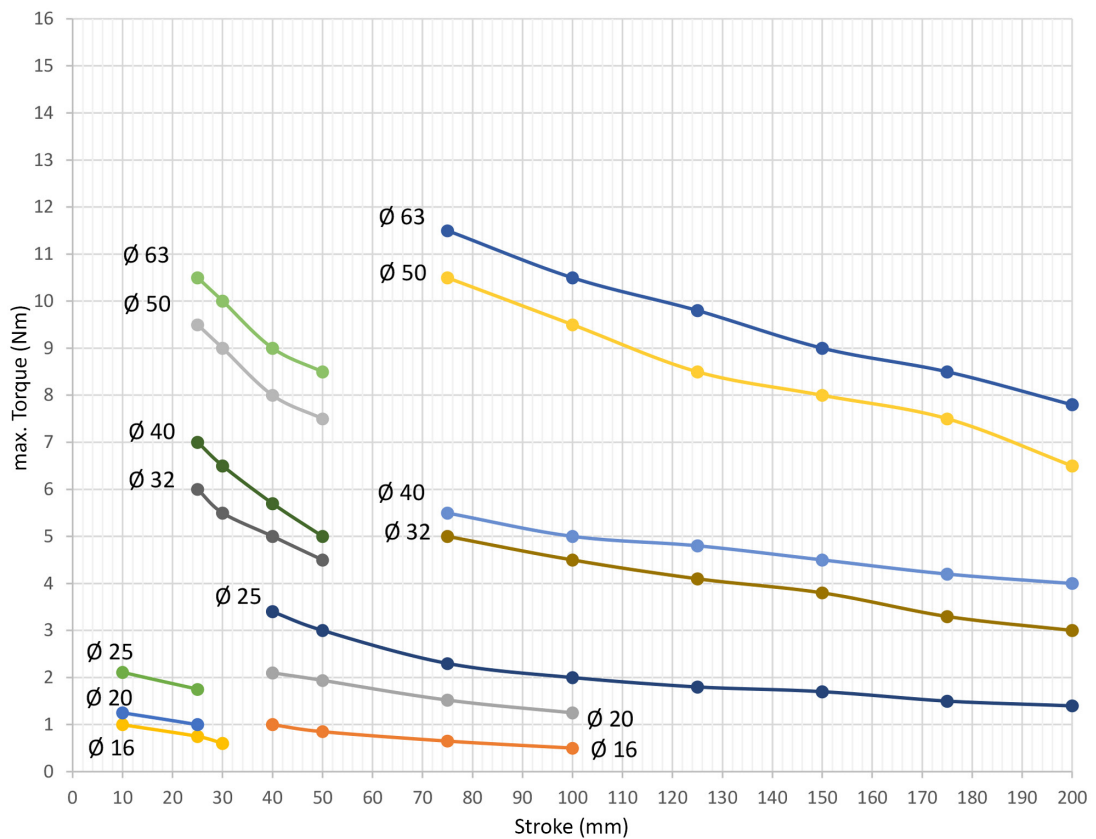

Series LXA

guide unit, double acting

Dimensions bronze bearings, built-in cushioning rings

Dimension	Stroke	Piston Ø	16	20	25	32	40	50	63
A+	0-50		42	53	53,5	97	91	106,5	106,5
A+	75-200		64,5	84,5	85	102	102	118	118
B+			46	53	53,5	59,5	66	72	77
C+			33	37	37,5	37,5	44	44	49
ØDA			8	10	10	12	12	16	16
ØDB			10	12	16	20	20	25	25
E	0-50		0	0	0	37,5	31	34,5	29,5
E	75-200		18,5	31,5	31,5	42,5	36	46	41
FA			8	10	10	10	10	15	15
FB			5	6	6	12	12	13	13
G			30,5	36,8	42,8	49	55	65	79
GA			11	11,5	11,5	12	15	15	15,5
GB			8	9	10	9	12	12	13,5
H			64	84	94	113	121	149	163
HA			M4	M5	M5	M6	M6	M8	M10
HB			32,5	41,5	46,5	56	60	74	81
HC			32	42,5	47,5	57	61	75	82
J			15	18	21	24	27	32	39
K			15,5	18,8	21,8	25	28	33	40
L			22	24	30	34	40	46	58
MM			M5	M5	M6	M8	M8	M10	M10
ML			12	13	15	16	16	20	22
NN			M5	M5	M6	M8	M8	M10	M10
OA			4,2	5,2	5,2	6,5	6,5	8,5	8,5
OB			8	9,5	9,5	11	11	14	14
OL			4,5	5,5	5,5	7,5	7,5	9	9
P			M5	G1/8	G1/8	G1/8	G1/8	G1/4	G1/4
PA+			15	13,5	12,5	6,5	13	9	13
PB			10	11	14	16	18	21,5	28
PW			19	25	30	35,5	39,5	47	58
Q			16	18	26	30	30	40	50
R			54	70	78	96	104	130	130
S			25	30	40	45	45	60	70
T			62	81	91	110	118	146	158
U			46	54	64	78	86	110	124
VA			56	72	82	98	106	130	142
VN			38	44	50	63	72	92	110
VC			10,5	12,5	15	19,5	25	33	34
WA	0-30		24	24	24	24	24	24	28
WA	40-100		44	44	44	48	48	48	52
WA	125-200		110	120	120	124	124	124	128
WB	0-30		17	29	29	33	34	36	38
WB	40-100		27	39	39	45	46	48	50
WB	125-200		60	77	77	83	84	86	88
X			24	28	34	42	50	66	80
ØXA			3	3	4	4	4	5	5
XB			3,5	3,5	4,5	4,5	4,5	6	6
XC			3	3	3	3	3	4	4
XL			6	6	6	6	6	8	8
YY			M5	M6	M6	M8	M8	M10	M10
YL			10	12	12	16	16	20	22
Z			5	17	17	21	22	24	24
a			4,4	5,4	5,4	6,5	6,5	8,5	11
b			7,4	8,4	8,4	10,5	10,5	13,5	17,8
c			3,7	4,5	4,5	5,5	5,5	7,5	10
d			3,5	3,6	3,8	4,5	5	5,5	8
e			6,7	8,6	9	10,5	10,5	14,5	19,5

Dimensions bronze bearings, built-in cushioning rings

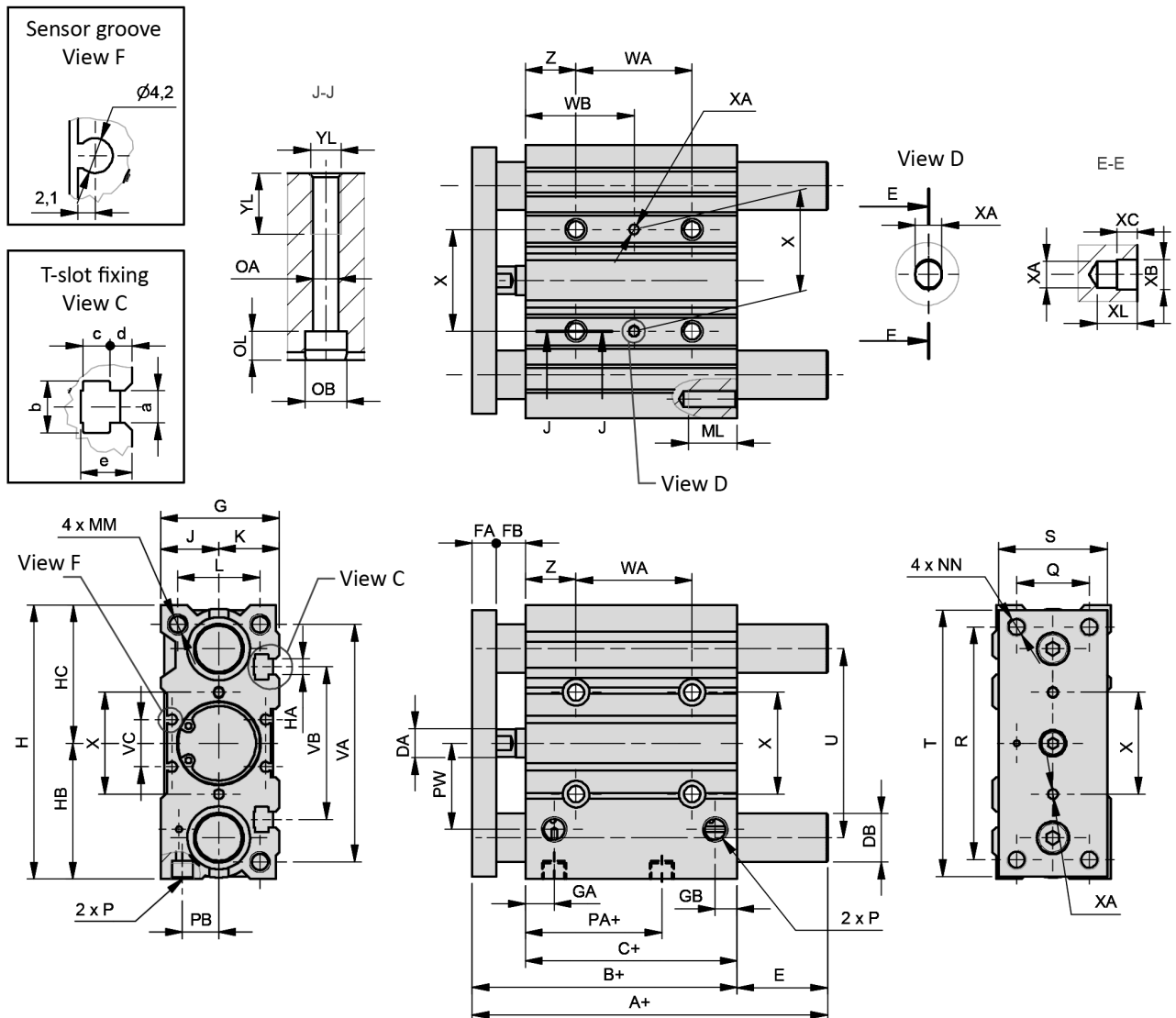

Piston \varnothing	Standard stroke lengths (mm)											
	10	20	30	40	50	75	100	125	150	175	200	
16												
20												
25												
32												
40												
50												
63												

Intermediate strokes are made with the profile of the standard superior stroke and with an internal spacer which limits the stroke to the required one.

Series LXA

guide unit, double acting

Dimensions ball bearings, built-in cushioning rings

Dimension	Stroke	Piston Ø	16	20	25	32	40	50	63
A+	0-30		49	63	69,5	-	-	-	-
A+	40-100		65	80	86	-	-	-	-
A+	125-200		-	104	104,5	-	-	-	-
A+	0-50		-	-	-	81	81	93	93
A+	75-100		-	-	-	98	98	114	114
A+	125-200		-	-	-	118	118	134	134
B+			46	53	53,5	59,5	66	72	77
C+			33	37	37,5	37,5	44	44	49
ØDA			8	10	10	12	12	16	16
ØDB			8	12	14	20	20	25	25
E	0-30		3	10	16	-	-	-	-
E	40-100		19	27	32,5	-	-	-	-
E	125-200		-	51	51	-	-	-	-
E	0-50		-	-	-	21,5	15	21	16
E	75-100		-	-	-	38,5	32	42	37
E	125-200		-	-	-	58,5	52	62	57
FA			8	10	10	10	10	15	15
FB			5	6	6	12	12	13	13
G			30,5	36,8	42,8	49	55	65	79
GA			11	11,5	11,5	12	15	15	15,5
GB			8	9	10	9	12	12	13,5
H			64	84	94	113	121	149	163
HA			M4	M5	M5	M6	M6	M8	M10
HB			32,5	41,5	46,5	56	60	74	81
HC			32	42,5	47,5	57	61	75	82
J			15	18	21	24	27	32	39
K			15,5	18,8	21,8	25	28	33	40
L			22	24	30	34	40	46	58
MM			M5	M5	M6	M8	M8	M10	M10
ML			12	13	15	16	16	20	22
NN			M5	M5	M6	M8	M8	M10	M10
OA			4,2	5,2	5,2	6,5	6,5	8,5	8,5
OB			8	9,5	9,5	11	11	14	14
OL			4,5	5,5	5,5	7,5	7,5	9	9
P			M5	G1/8	G1/8	G1/8	G1/8	G1/4	G1/4
PA+			15	13,5	12,5	6,5	13	9	13
PB			10	11	14	16	18	21,5	28
PW			19	25	30	35,5	39,5	47	58
Q			16	18	26	30	30	40	50
R			54	70	78	96	104	130	130
S			25	30	40	45	45	60	70
T			62	81	91	110	118	146	158
U			46	54	64	78	86	110	124
VA			56	72	82	98	106	130	142
VN			38	44	50	63	72	92	110
VC			10,5	12,5	15	19,5	25	33	34
WA	0-30		24	24	24	24	24	24	28
WA	40-100		44	44	44	48	48	48	52
WA	125-200		110	120	120	124	124	124	128
WB	0-30		17	29	29	33	34	36	38
WB	40-100		27	39	39	45	46	48	50
WB	125-200		60	77	77	83	84	86	88
X			24	28	34	42	50	66	80
ØXA			3	3	4	4	4	5	5
XB			3,5	3,5	4,5	4,5	4,5	6	6
XC			3	3	3	3	3	4	4
XL			6	6	6	6	6	8	8
YY			M5	M6	M6	M8	M8	M10	M10
YL			10	12	12	16	16	20	22
Z			5	17	17	21	22	24	24
a			4,4	5,4	5,4	6,5	6,5	8,5	11
b			7,4	8,4	8,4	10,5	10,5	13,5	17,8
c			3,7	4,5	4,5	5,5	5,5	7,5	10
d			3,5	3,6	3,8	4,5	5	5,5	8
e			6,7	8,6	9	10,5	10,5	14,5	19,5

Dimensions ball bearings, built-in cushioning rings

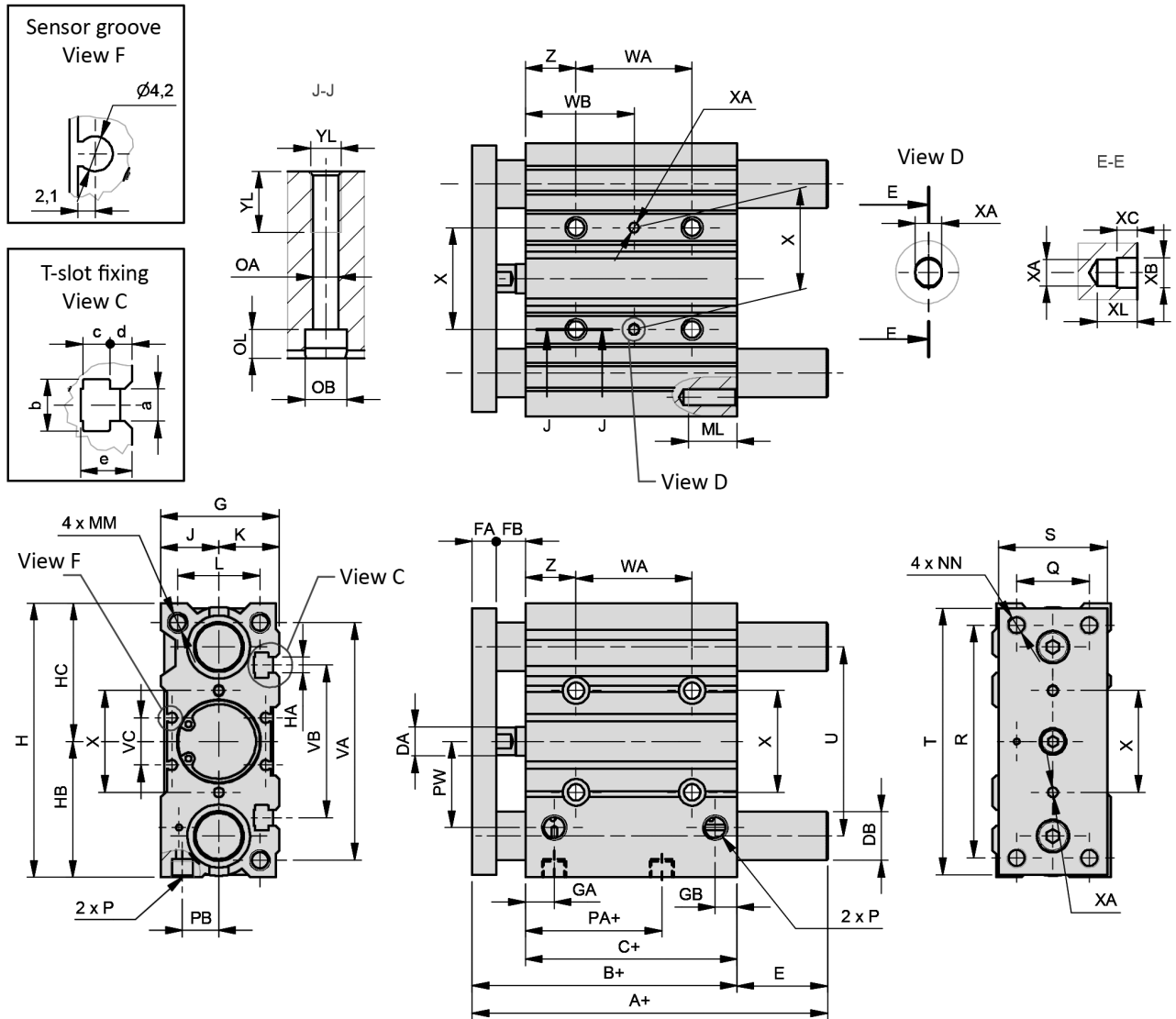

Piston \varnothing	Standard stroke lengths (mm)											
	10	20	30	40	50	75	100	125	150	175	200	
16												
20												
25												
32												
40												
50												
63												

Intermediate strokes are made with the profile of the standard superior stroke and with an internal spacer which limits the stroke to the required one.

Series LXA

guide unit, double acting

Dimensions bronze bearings, adjustable cushioning

Dimension	Stroke	Piston Ø	16	20	25	32	40	50	63
A+	0-25		71	78	78,5	97	97	106,5	106,5
A+	30-50		71	86,5	87	127	127	131,5	131,5
A+	75-200		71	84,5	85	102	102	118	118
B+			71	78	78,5	84,5	91	97	102
C+			58	62	62,5	62,5	69	69	74
ØDA			8	10	10	12	12	16	16
ØDB			10	12	16	20	20	25	25
E	0-25		0	0	0	12,5	6	9,5	4,5
E	30-50		0	8,5	8,5	42,5	36	34,5	29,5
E	75-200		0	6,5	6,5	17,5	11	21	16
FA			8	10	10	10	10	15	15
FB			5	6	6	12	12	13	13
G			30,5	36,8	42,8	49	55	65	79
GA			11	11,5	11,5	12	15	15	15,5
GB			8	9	10	9	12	12	13,5
H			64	84	94	113	121	149	163
HA			M4	M5	M5	M6	M6	M8	M10
HB			32,5	41,5	46,5	56	60	74	81
HC			32	42,5	47,5	57	61	75	82
J			15	18	21	24	27	32	39
K			15,5	18,8	21,8	25	28	33	40
L			22	24	30	34	40	46	58
MM			M5	M5	M6	M8	M8	M10	M10
ML			12	13	15	16	16	20	22
NN			M5	M5	M6	M8	M8	M10	M10
OA			4,2	5,2	5,2	6,5	6,5	8,5	8,5
OB			8	9,5	9,5	11	11	14	14
OL			4,5	5,5	5,5	7,5	7,5	9	9
P			M5	G1/8	G1/8	G1/8	G1/8	G1/4	G1/4
PA+			40	38,5	37,5	31,5	38	34	38
PB			10	10,5	13,5	16	18	21,5	28
PW			19	25	30	35,5	39,5	47	58
Q			16	18	26	30	30	40	50
R			54	70	78	96	104	130	130
S			25	30	40	45	45	60	70
T			62	81	91	110	118	146	158
U			46	54	64	78	86	110	124
VA			56	72	82	98	106	130	142
VN			38	44	50	63	72	92	110
VC			10,5	12,5	15	19,5	25	33	34
WA	0-75		44	44	44	48	48	48	52
WA	100-175		110	120	120	124	124	124	128
WA	200		/	200	200	200	200	200	200
WB	0-75		27	39	39	45	46	48	50
WB	100-175		60	77	77	83	84	86	88
WB	200		/	117	117	121	122	124	124
X			24	28	34	42	50	66	80
ØXA			3	3	4	4	4	5	5
XB			3,5	3,5	4,5	4,5	4,5	6	6
XC			3	3	3	3	3	4	4
XL			6	6	6	6	6	8	8
YY			M5	M6	M6	M8	M8	M10	M10
YL			10	12	12	16	16	20	22
Z			5	17	17	21	22	24	24
a			4,4	5,4	5,4	6,5	6,5	8,5	11
b			7,4	8,4	8,4	10,5	10,5	13,5	17,8
c			3,7	4,5	4,5	5,5	5,5	7,5	10
d			3,5	3,6	3,8	4,5	5	5,5	8
e			6,7	8,6	9	10,5	10,5	14,5	19,5

Dimensions bronze bearings, adjustable cushioning

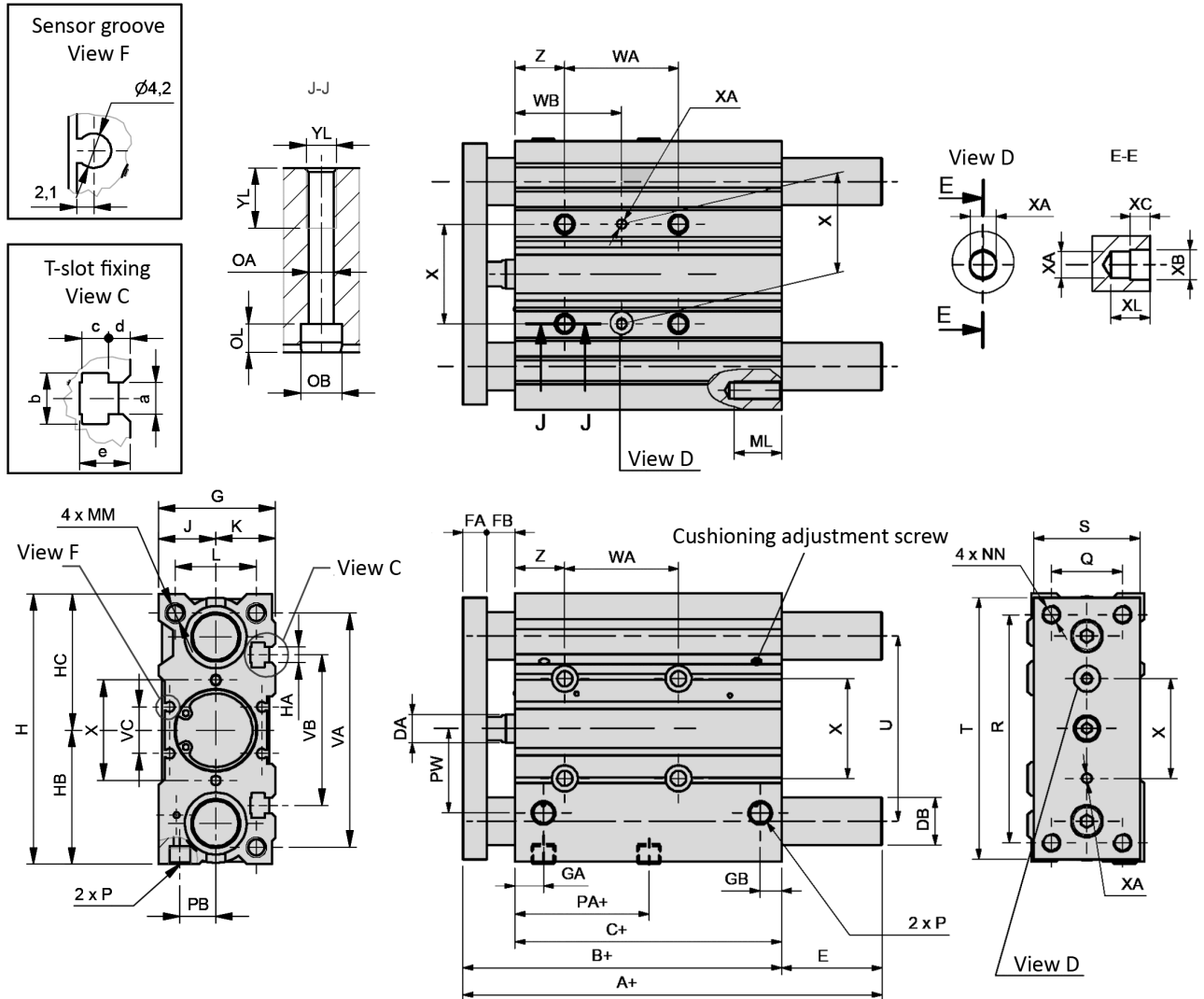

Piston Ø	Standard stroke lengths (mm)										
	20	25	30	40	50	75	100	125	150	175	200
16	20	25	30	40	50	75	100				
20	20	25	30	40	50	75	100	125	150	175	200
25	20	25	30	40	50	75	100	125	150	175	200
32		25			50	75	100	125	150	175	200
40		25			50	75	100	125	150	175	200
50		25			50	75	100	125	150	175	200
63		25			50	75	100	125	150	175	200

Intermediate strokes are made with the profile of the standard superior stroke and with an internal spacer which limits the stroke to the required one.

Series LXA

guide unit, double acting

Dimensions ball bearings, adjustable cushioning

Dimension	Stroke	Piston Ø	16	20	25	32	40	50	63
A+	0-25		71	95	100,5	84,5	91	97	102
A+	50		71	80	85,5	123	123	127,5	127,5
A+	75		71	80	85,5	98	98	114	114
A+	100		71	99	99,5	115,5	115,5	159	159
A+	125-200		-	104	104,5	118	118	134	134
B+			71	78	78,5	84,5	91	97	102
C+			58	62	62,5	62,5	69	69	74
ØDA			8	10	10	12	12	16	16
ØDB			8	12	14	20	20	25	25
E	0-25		0	17	22	0	0	0	0
E	50		0	2	7	38,5	32	30,5	25,5
E	75		0	2	7	13,5	7	17	12
E	100		0	21	26	31	24,5	62	57
E	125-200		-	26	26	33,5	27	37	32
FA			8	10	10	10	10	15	15
FB			5	6	6	12	12	13	13
G			30,5	36,8	42,8	49	55	65	79
GA			11	11,5	11,5	12	15	15	15,5
GB			8	9	10	9	12	12	13,5
H			64	84	94	113	121	149	163
HA			M4	M5	M5	M6	M6	M8	M10
HB			32,5	41,5	46,5	56	60	74	81
HC			32	42,5	47,5	57	61	75	82
J			15	18	21	24	27	32	39
K			15,5	18,8	21,8	25	28	33	40
L			22	24	30	34	40	46	58
MM			M5	M5	M6	M8	M8	M10	M10
ML			12	13	15	16	16	20	22
NN			M5	M5	M6	M8	M8	M10	M10
OA			4,2	5,2	5,2	6,5	6,5	8,5	8,5
OB			8	9,5	9,5	11	11	14	14
OL			4,5	5,5	5,5	7,5	7,5	9	9
P			M5	G1/8	G1/8	G1/8	G1/8	G1/4	G1/4
PA+			40	38,5	37,5	31,5	38	34	38
PB			10	10,5	13,5	16	18	21,5	28
PW			19	25	30	35,5	39,5	47	58
Q			16	18	26	30	30	40	50
R			54	70	78	96	104	130	130
S			25	30	40	45	45	60	70
T			62	81	91	110	118	146	158
U			46	54	64	78	86	110	124
VA			56	72	82	98	106	130	142
VN			38	44	50	63	72	92	110
VC			10,5	12,5	15	19,5	25	33	34
WA	0-75		44	44	44	48	48	48	52
WA	100-175		110	120	120	124	124	124	128
WA	200		/	200	200	200	200	200	200
WB	0-75		27	39	39	45	46	48	50
WB	100-175		60	77	77	83	84	86	88
WB	200		/	117	117	121	122	124	124
X			24	28	34	42	50	66	80
ØXA			3	3	4	4	4	5	5
XB			3,5	3,5	4,5	4,5	4,5	6	6
XC			3	3	3	3	3	4	4
XL			6	6	6	6	6	8	8
YY			M5	M6	M6	M8	M8	M10	M10
YL			10	12	12	16	16	20	22
Z			5	17	17	21	22	24	24
a			4,4	5,4	5,4	6,5	6,5	8,5	11
b			7,4	8,4	8,4	10,5	10,5	13,5	17,8
c			3,7	4,5	4,5	5,5	5,5	7,5	10
d			3,5	3,6	3,8	4,5	5	5,5	8
e			6,7	8,6	9	10,5	10,5	14,5	19,5

Dimensions ball bearings, adjustable cushioning

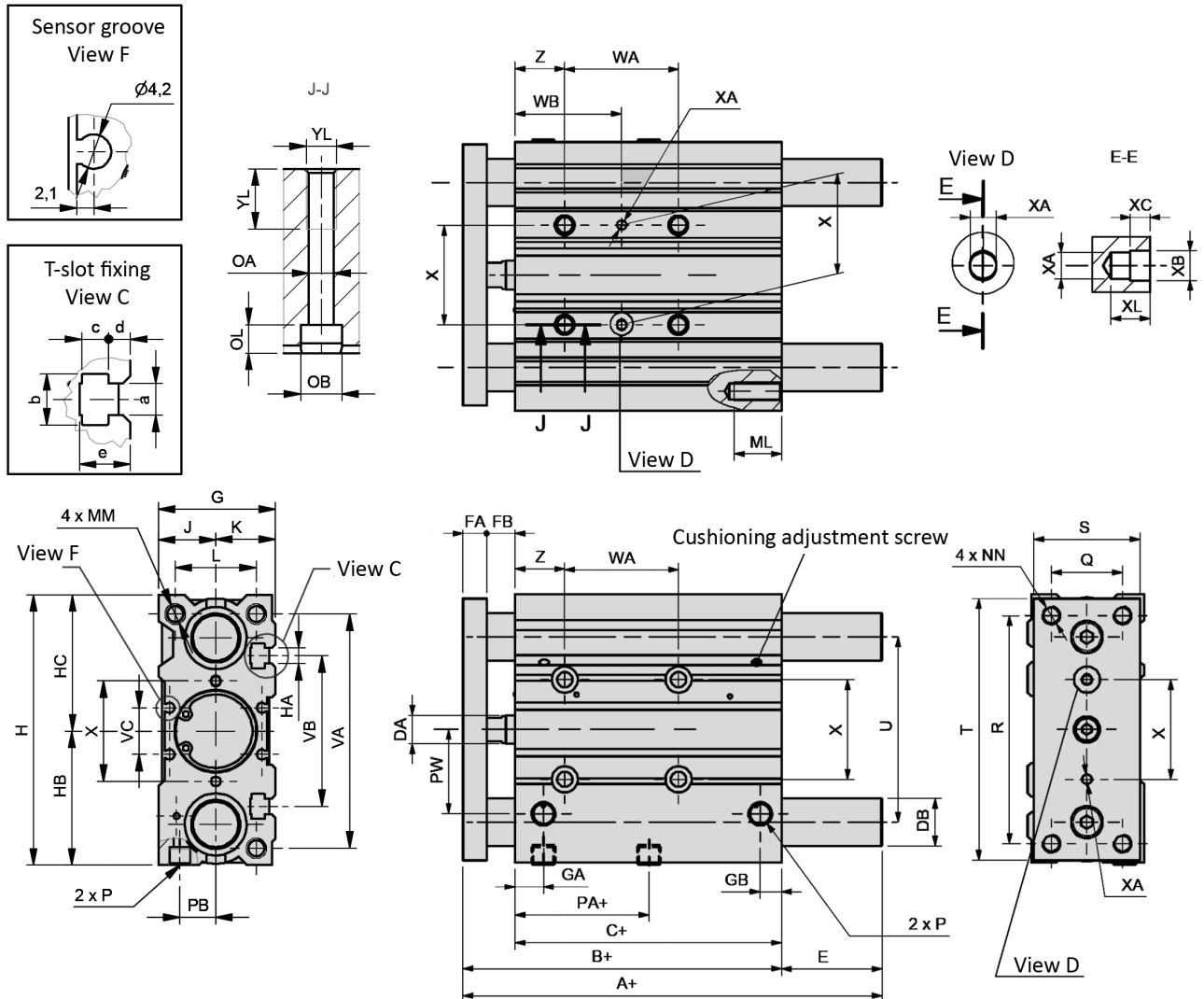

Piston ϕ	Standard stroke lengths (mm)										
	20	25	30	40	50	75	100	125	150	175	200
16	20	25	30	40	50	75	100				
20	20	25	30	40	50	75	100	125	150	175	200
25	20	25	30	40	50	75	100	125	150	175	200
32		25			50	75	100	125	150	175	200
40		25			50	75	100	125	150	175	200
50		25			50	75	100	125	150	175	200
63		25			50	75	100	125	150	175	200

Intermediate strokes are made with the profile of the standard superior stroke and with an internal spacer which limits the stroke to the required one.

Series ZS Proximity sensors

Proximity sensors with cable

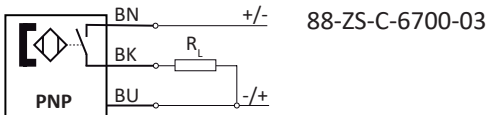
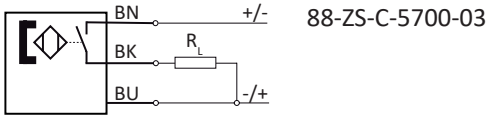
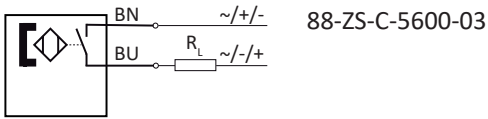

Proximity sensors with plug

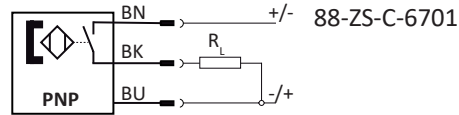
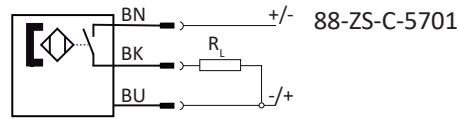

Technical data

Model-no.:	88-ZS-C-5600-03	88-ZS-C-5700-03
Mounting	C-Nut	C-Nut
Design	2-pole Reed sensor	3-pole Reed sensor
Contact function	NO	NO
Output		
Rated operational voltage	5 ... 120 V AC / DC	5 ... 30 V DC
Rated operational current I_e	≤ 100 mA	≤ 300 mA
Max. voltage drop at I_e	≤ 2,5	≤ 0,1
Breaking capacity	3,5 W	3,5 W
Cable length	3 m	3 m
Temperature range	-10 ... +70°C	-10 ... +70°C
Protection	IP 67	IP 67
Switching status indication	LED red	LED yellow

Technical data

Model-no.:	88-ZS-C-5701	88-ZS-C-6700-03	88-ZS-C-6701
			
Mounting	C-Nut	C-Nut	C-Nut
Design	3-pole Reed sensor	3-pole inductive	3-pole inductive
Contact function	NO	NO	NO
Output		PNP	PNP
Rated operational voltage	5 ... 30 V DC	5 ... 30 V DC	5 ... 30 V DC
Rated operational current I_E	≤ 300 mA	≤ 200 mA	≤ 200 mA
Max. voltage drop at I_E	≤ 0,1	≤ 0,5	≤ 0,5
Breaking capacity	3,5 W	6 W	6 W
Cable length	0,15 m with M8 connection	3 m	0,15 m with M8 connection
Temperature range	-10 ... +70°C	-10 ... +70°C	-10 ... +70°C
Protection	IP 67	IP 67	IP 67
Switching status indication	LED yellow	LED red	LED red

Cable with bushing for proximity sensors

Model-no.:	KA-30	KA-50	KA-51	KA-100	KA-101
Connection	M8, snap-in	M8, snap-in	M8, snap-in	M8, snap-in	M8, snap-in
Version	straight	straight	elbow 90°	straight	elbow 90°
Cable length	3 m	5 m	5 m	10 m	10 m

Mounting

The sensors are mounted at the groove of the cylinder profile. It is fixed by turning the fixing screw at the sensor clockwise.